

Standby Power Rating

130 kW 60 Hz

Liquid Cooled Gas Engine Generator Sets



Whisper-Test™
Low Speed Exercise
65 dB(A) at 23 feet

GENERAC 6.8L ENGINE

Naturally Aspirated
Gaseous Fueled

UL 2200 Listed

Transfer Switch is sold separately

STANDARD EQUIPMENT

- All input connections in one single area
- High coolant temperature shutdown
- Low oil pressure shutdown
- Low coolant level automatic shutdown
- Low fuel pressure
- Overspeed automatic shutdown
- Adjustable cranking timer
- Adjustable exercise timer
- Oil drain extension
- Cool flow radiator
- Closed coolant recovery system
- UV/Ozone resistant hoses
- Watertight state of the art electrical connectors
- Mainline circuit breaker
- Oil drain extension to frame rail
- Radiator drain extension
- Battery charge alternator
- 2 Amp static battery charger
- Battery, battery rack and battery cables
- Fan and belt guards
- Isochronous governor
- Flex fuel line pigtail

FEATURES

- Innovative design and fully prototype tested
- UL 2200 Listed
- Solid state frequency compensated voltage regulator
- Dynamic and static battery charger
- Sound attenuated acoustically designed enclosure
- *Whisper-Test™* for low noise level exercise
- Acoustically designed engine cooling system
- High flow low noise factory engineered exhaust system
- State of the art digital control system with H-100 microprocessor control panel
- Built-in kW, kVAR and power factor meters
- Watertight electrical connectors
- Rodent proof construction
- High efficiency, low distortion Generac designed alternator
- Vibration isolated from mounting base
- Matching Generac transfer switches engineered and tested to work as a system
- All components easily accessible for maintenance
- Electrostatically applied powder paint

GUARDIAN Elite™
by Generac Power Systems, Inc.

COMMERCIAL SERIES

GENERATOR SPECIFICATIONS

TYPE.....	Synchronous
ROTOR INSULATION.....	Class H
STATOR INSULATION.....	Class H
TOTAL HARMONIC DISTORTION.....	<3.5%
TELEPHONE INTERFERENCE FACTOR (TIF).....	<50
ALTERNATOR OUTPUT LEADS 3 PHASE.....	4 wire
BEARINGS.....	Sealed Ball
COUPLING.....	Gear Drive
LOAD CAPACITY (STANDBY RATING).....	130 kW
EXCITATION SYSTEM.....	Brushless

NOTE: Generator rating and performance in accordance with ISO8528-5, BS5514, SAE J1349, ISO3046, and DIN6271 standards.

VOLTAGE REGULATOR

TYPE.....	Full Digital
SENSING.....	3 Phase
REGULATION.....	± 1/4%
FEATURES.....	Built into H-100 Control Panel V/F Adjustable Adjustable Voltage and Gain

GENERATOR FEATURES

- Revolving field heavy duty generator
- Quiet drive coupling
- Operating temperature rise 120 °C above a 40 °C ambient
- Insulation is Class H rated at 150 °C rise
- All prototype models have passed three phase short circuit testing

CONTROL PANEL FEATURES

- TWO FOUR LINE LCD DISPLAYS READ:
 - Voltage (all phases)
 - Power factor
 - kVAR
 - Engine speed
 - Run hours
 - Fault history
 - Coolant temperature
 - Low oil pressure shutdown
 - Overvoltage
 - Low coolant level
 - Not in auto position (flashing light)
 - Current (all phases)
 - kW
 - Transfer switch status
 - Low fuel pressure
 - Service reminders
 - Oil pressure
 - Time and date
 - High coolant temperature shutdown
 - Overspeed
 - ATS selection
 - Exercise speed
- INTERNAL FUNCTIONS:
 - I²T function for alternator protection from line to neutral and line to line short circuits
 - Emergency stop
 - Programmable auto crank function
 - 2 wire start for any transfer switch
 - Communicates with the Generac HTS transfer switch
 - Built-in 7 day exerciser
 - Adjustable engine speed at exerciser
 - RS232 port for GenLink® control
 - RS485 port remote communication
 - Canbus addressable
 - Governor controller and voltage regulator are built into the master control board
 - Temperature range -40 °C to 70 °C

ENGINE SPECIFICATIONS

MAKE.....	Generac
MODEL.....	V Type
CYLINDERS.....	10
DISPLACEMENT.....	6.8 Liter
BORE.....	3.55
STROKE.....	4.17
COMPRESSION RATIO.....	9:1
INTAKE AIR SYSTEM.....	Naturally Aspirated
VALVE SEATS.....	Hardened
LIFTER TYPE.....	Hydraulic

GOVERNOR SPECIFICATIONS

TYPE.....	Electronic
FREQUENCY REGULATION.....	Isochronous
STEADY STATE REGULATION.....	± 0.25%

All functions are factory preset.
Individual parameter adjustments can be made via GenLink®.

ENGINE LUBRICATION SYSTEM

OIL PUMP.....	Gear
OIL FILTER.....	Full flow spin-on cartridge
CRANKCASE CAPACITY.....	5 Quarts

ENGINE COOLING SYSTEM

TYPE.....	Closed
WATER PUMP.....	Belt driven
FAN SPEED.....	1950
FAN DIAMETER.....	26 inches
FAN MODE.....	Puller

FUEL SYSTEM

FUEL TYPE.....	Natural gas, propane vapor
CARBURETOR.....	Down Draft
SECONDARY FUEL REGULATOR.....	Standard
FUEL SHUT OFF SOLENOID.....	Standard
OPERATING FUEL PRESSURE.....	11" - 14" H ₂ O

ELECTRICAL SYSTEM

BATTERY CHARGE ALTERNATOR.....	12V 30 Amp
STATIC BATTERY CHARGER.....	12V 2 Amp
RECOMMENDED BATTERY.....	Group 24F, 525 CCA
SYSTEM VOLTAGE.....	12 Volts

COMMERCIAL 130 KW

OPERATING DATA

		COMMERCIAL 130 KW		
KW RATING		130		
ENGINE SIZE		6.8 Liter V-10		
GENERATOR OUTPUT VOLTAGE/KW - 60Hz		KW	AMP	CB Size
120/240V, single phase, 1.0 pf		130	541.6	600
120/208V, 3-phase, 0.8 pf		130	451.5	500
120/240V, 3-phase, 0.8 pf		130	391.3	450
277/480V, 3-phase, 0.8 pf		130	195.6	225
GENERATOR LOCKED ROTOR KVA AVAILABLE @ VOLTAGE DIP OF 35%				
Single phase or 208V & 240V 3-phase		270		
480V 3-phase		320		
ENGINE FUEL CONSUMPTION (Natural Gas) (Propane)		Natural Gas (ft ³ /hr.)	Propane (gal/hr.)	cu ft/hr
Exercise cycle		135	1.48	54.5
25% of rated load		482	5.28	194.3
50% of rated load		927	10.15	373.5
75% of rated load		1292	14.15	520.7
100% of rated load		1786	19.56	719.8
ENGINE COOLING				
Air flow (inlet air including alternator and combustion air)	ft ³ /hr.	6,450		
System coolant capacity	US gal.	4.5		
Heat rejection to coolant	BTU/hr.	496,000		
Max. operating air temp. on radiator	°C (°F)	60 (150)		
Max. ambient temperature	°C (°F)	50 (140)		
COMBUSTION AIR REQUIREMENTS				
Flow at rated power 60 Hz	cfm	336		
SOUND EMISSIONS IN DBA				
db(A) @ 23 feet in exercise mode		65		
db(A) @ 23 feet at normal operating load		75		
EXHAUST				
Exhaust flow at rated output 60 Hz	cfm	1,119		
Exhaust temp. at muffler outlet	°F	970		
ENGINE PARAMETERS				
Rated synchronous RPM	60 Hz	3000		
HP at rated KW	60 Hz	210		
POWER ADJUSTMENT FOR AMBIENT CONDITIONS				
Temperature Deration				
3% for every 10 °C above - °C		25		
1.65% for every 10 °F above - °F		77		
Altitude Deration				
1% for every 100 m above - m		183		
3% for every 1000 ft. above - ft.		600		

RATING: All three phases units are rated at 0.8 power factor. All single phase units are rated at 1.0 power factor. STANDBY RATING: Standby ratings apply to installations served by a reliable utility source. The standby rating is applicable to varying loads for the duration of a power outage. There is no overload capability for this rating. Ratings are in accordance with ISO-3046-1. Design and specifications are subject to change without notice. Maximum wattage and current are subject to and limited by such factors as fuel Btu content, ambient temperature, altitude, engine power and condition, etc.

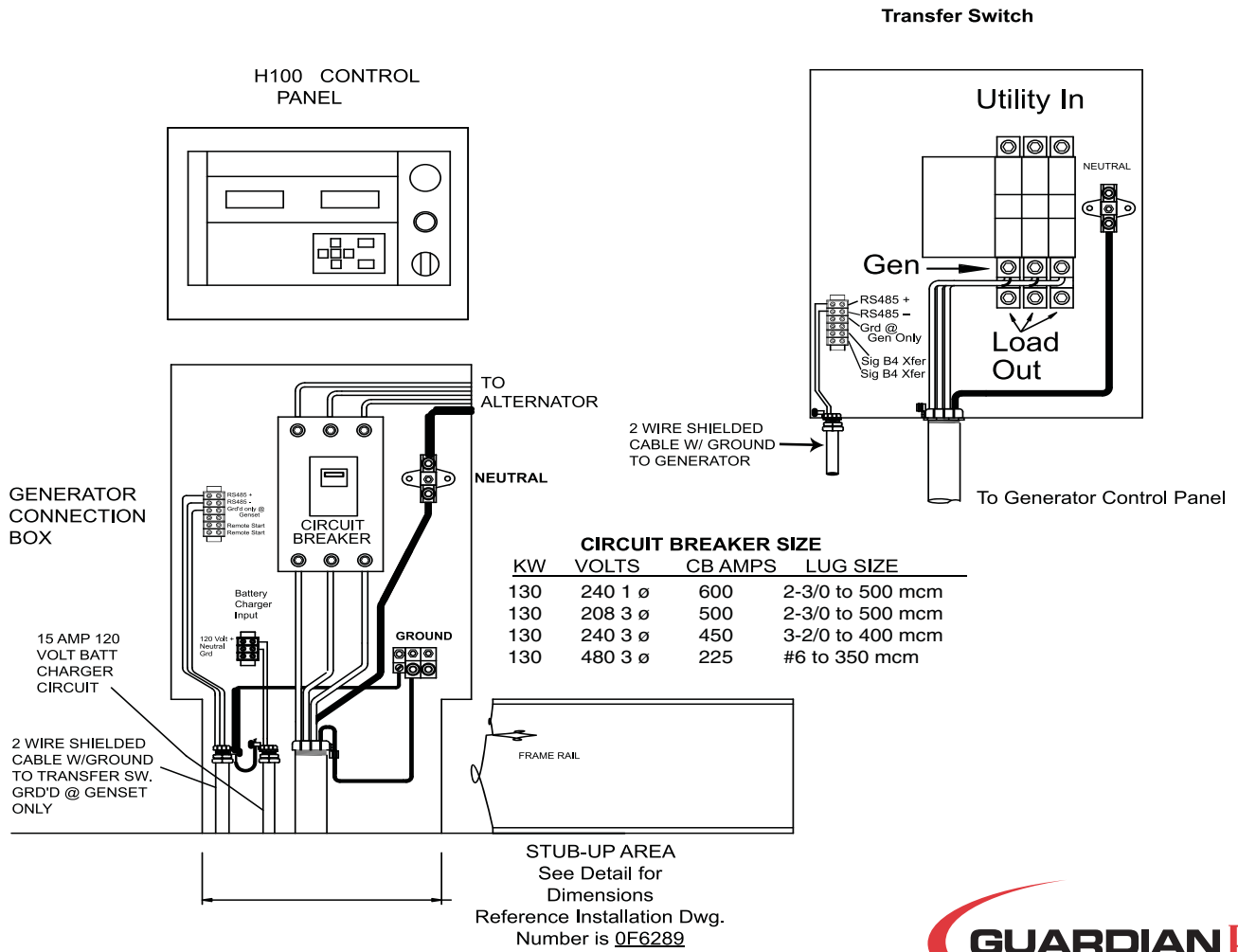

INSTALLATION LAYOUT

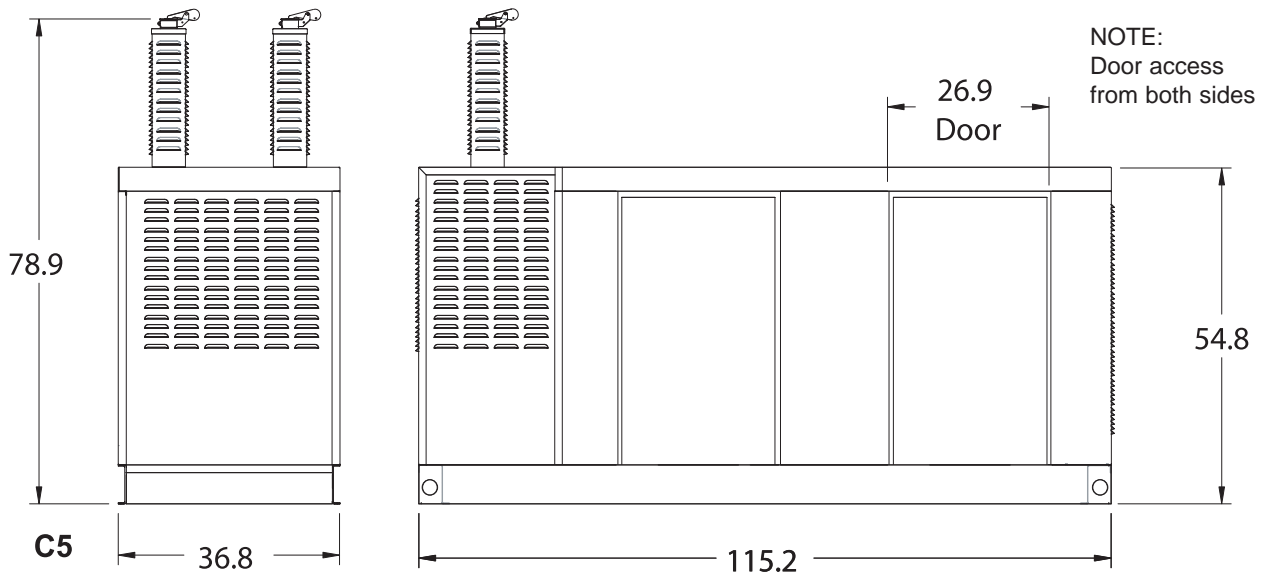

UNIT WEIGHT: Steel 2873 lbs., Aluminum 2699 lbs.